

# QSK T/R Switch for your Vintage Boat-Anchor Station

Phil Salas – AD5X

## Introduction

As a CW operator, I enjoy full break-in operation with my Elecraft K3 transceiver. However, my Johnson Ranger/Drake 2B vintage station employs a relay-based T/R switch controlled by the Ranger's 120VAC relay control output. So T/R switching occurs by switching the Ranger from "Standby" to "CW". Because I miss full break-in when operating my vintage station, I decided it was time to look into a QSK T/R switch.

## A relay-based QSK solution

Like modern transceivers, the typical RF output of most vintage transmitters is 200 watts or less. This level can be handled by very fast miniature signal relays. For example, 100 watts into 50 ohms requires that the output relay carries 1.4-amps rms. The OMRON signal relays I chose can handle 3-amps of current (2-amps when hot-switched), as well as 1000V RMS between open contacts and between the contacts and coil. Further, these relays switch in less than 5-milliseconds (typically 3ms) – perfect for QSK operation.

The switching portion of the QSK T/R relay switch is shown in Figure 1. Two DPDT relays are used. K1 handles CW keying and receiver mute control – though receiver muting is usually not used in CW so you can monitor your signal. K2 handles the transmitter output and receiver input antenna routing. K2 also grounds the receiver RF input when enabled to protect the receiver front-end from overload. The 22pf capacitor compensates for the relay and wiring inductance.

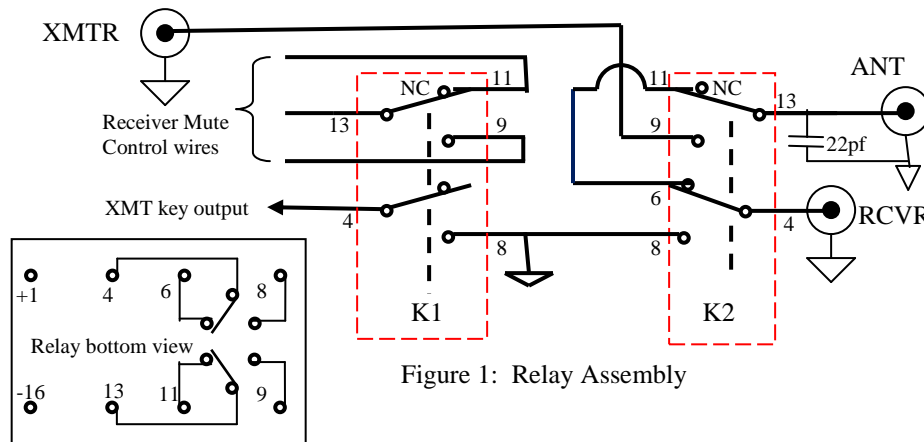

Figure 2 is the schematic of the relay driver circuitry. Switch S1 provides a constant-key input for tuning-up purposes or for manually enabling the T/R switch for phone operation. As you can see, you key the T/R switch and then the T/R switch both keys the transmitter and provides T/R antenna switching. The relay drive circuitry presents a low-current keying interface (less than 2ma) so any key or keyer can be used. Because transmitter keying is via relay contacts, any transmit keying input is fine – i.e. grid-block keying or cathode keying, or any other keying input.



1	1/8" stereo jack	161-7300-EX	\$1.02
2	Phono jacks	161-1052	\$1.09
1	SPST or SPDT switch	108-1AS1T1171-EVX	\$2.67
1	2.1x5.5mm DC power jack	163-1060-EX	\$0.88
3	SO239 chassis mount	601-25-7350	\$1.33
1	Project Box 4x4x2"	537-CR-442	\$12.90
2	16-pin IC socket	535-16-3518-10	\$1.37

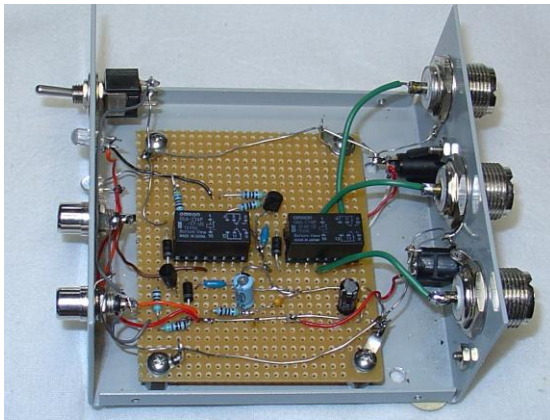

Photo A: Internal Wiring



Photo B: Front Panel Interfaces



Photo C: Rear Panel Interfaces

### Timing Measurements

I measured the relay timing just to make sure everything worked as required. Photo D shows the timing of the two relays. The upper trace is the keying/rcvr mute relay, and the lower trace is the antenna switching relay. As you can see, both relays are enabled simultaneously – i.e. the transmitter is keyed at exactly the same time as the antenna relay is switched. However when K1 unkeys the transmitter, K2 is delayed by about 10ms to give the RF time to fully decay. The equivalent CW keying speed is approximately 40WPM.

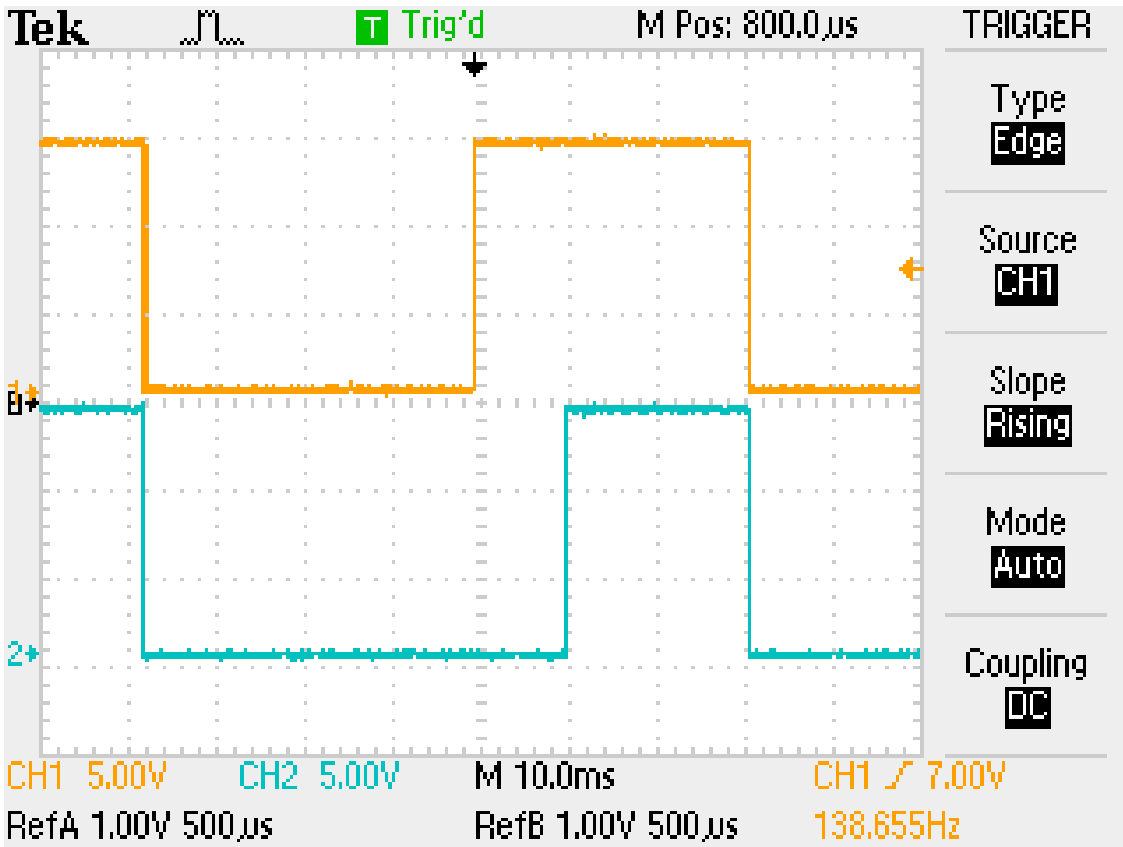

Photo D: Relay Timing. Yellow: Keying Relay K1. Blue: Antenna Switching Relay K2

### VSWR and Isolation Measurements

Photo E is a VSWR/Return loss scan of that QSK switch. Since your boat-anchor transmitter has a pi-network output and you tune it, a 10-meter VSWR of 1.3:1 isn't a big deal. I went ahead and compensated this a bit by adding a 22pf capacitor directly across the antenna port as you can see in Photo F.

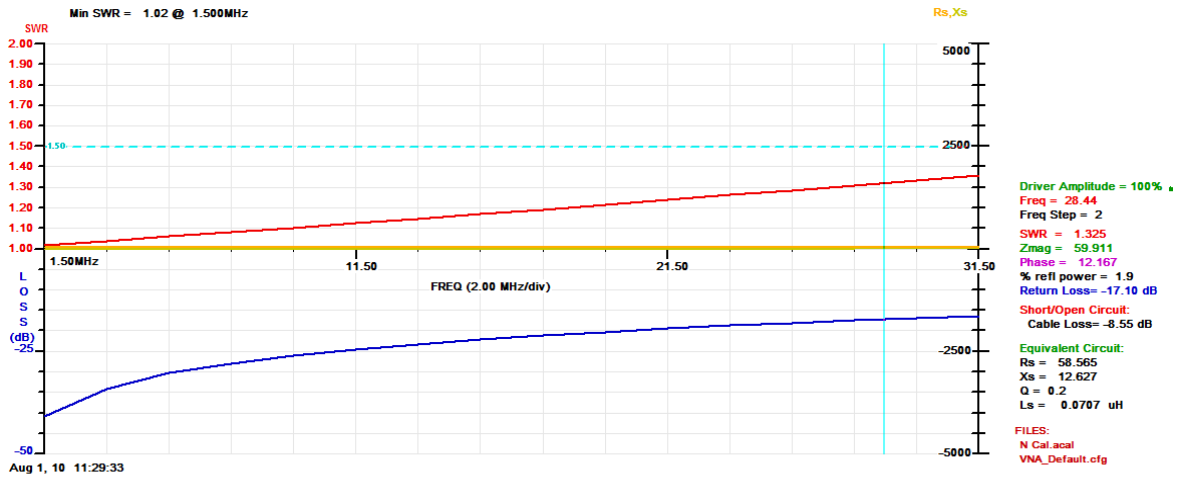

Photo E: Uncompensated VSWR/Return Loss scan

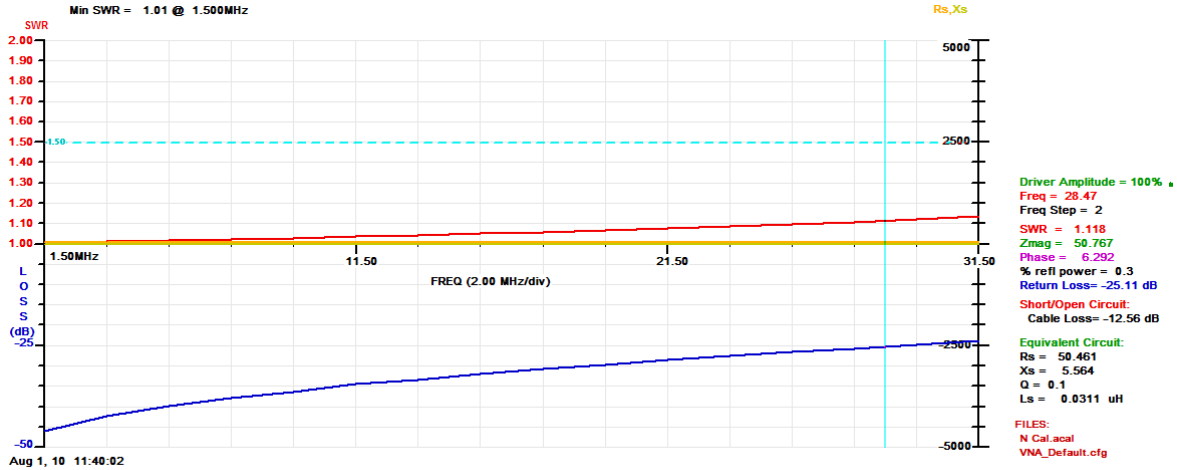

Photo F: 22pf Compensated VSWR/Return Loss Scan

Next I checked the transmit and receive port isolation (Photo G). The worst case isolation is about 40 dB on 10 meters. So a 100 watt transmitter on 10 meters will leak 10 milliwatts into the connected receiver's front end. This 0.707Vrms (2Vp-p) signal should not cause any problems to the front-end of any vacuum-tube receiver. And as you can see, the isolation improves as you go lower in frequency - typically 6dB/octave.

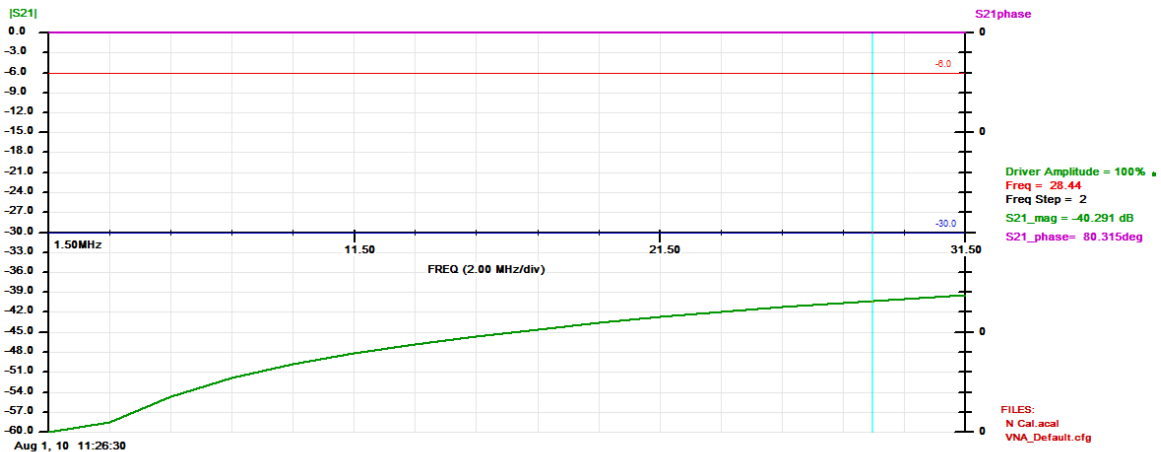

Photo G: Transmit/Receive Isolation

Operation is simple. Simply connect your key or keyer to the KEY input, and connect the KEY OUTPUT to your transmitter CW jack. Connect your coax cables to the appropriate connectors, and provide +13.8VDC power to the unit. If desired, you can connect your receiver muting inputs to the 1/8" stereo jack on the QSK switch (both NO and NC contacts are provided). To manually enable the T/R switch for transmitter tuning purposes or phone operation, simply set the front panel switch to TUNE. Set the switch to OPR for normal QSK operation.

### How Long will the Relays Last?

I did socket the relays so they could be easily replaced, however they should last a very long time. The relay life is specified at 100 million operations minimum at 36,000 operations/hour. And the relay life increases as the operations/hour decreases. So let's use the standard PARIS text that is used for determining code speed.

PARIS has 10 dits and 4 dahs = 14 relay operations/minute at 1 WPM.

Assuming an average of 25WPM code speed, you would have 360 relay operations per minute. So, 100 million operations = 4630 hours. Now you normally operate 50% transmitting and 50% receiving during a QSO, so your relay operating time should double to 9260 hours. There are 8760 hours/year, which means you could operate 1.057 years at 25 WPM before the relays exceeded their lifetime spec – IF you operate 24 hours/day! Now you probably listen more like 75% of the time and are in a QSO 25% of the time. So this says that your relay operating life will be over 4-years if you operate 24 hours/day. To be a little more realistic, let's say you average 4-hours/day of operation (probably more than most folks). This extends the relay life to about 25 years! Of course, your mileage may vary.

### Conclusion

I've described an external T/R switch that is fast enough to permit full break-in operation with a separate transmitter-receiver set-up such as you would find in '60s and earlier ham stations. If you want to really enjoy CW with your vintage ham station, this QSK T/R switch will certainly enhance your operating pleasure.