

Johnson Ranger Modifications – Phil Salas AD5X

This write-up details the minimum modifications that I believe should be made to the Johnson Ranger. These mods include replacing all the old electrolytic and paper capacitors, solid-stating the power supplies, replacing the 1614 tubes with 6550 tubes, moving the VFO dropping resistor outside the VFO compartment, removing the heat generating R35 bleeder resistor, reducing heat during “standby”, and significantly increasing the reliability of the “drive” pot. I’ve tried to put these modifications into a step-by-step approach, and I’ve also listed sources and prices for the parts needed. I’ve also included intermediate tests to verify modifications before you get into too much trouble. These minimal modifications will result in a much cooler and more reliable Ranger. The origins of some of these mods are based on the excellent article by Tim Smith WA1HLR. However, I have not included the PTT and audio mods recommended by Tim primarily because I’m a CW guy.

Before starting, gather up the parts. Also, it will help to copy the internal Ranger pictures from the manual and highlight the parts to be changed. PLEASE keep in mind that the voltages inside the Ranger are HIGH and LETHAL. So be careful! Lets get to it. So, with the Ranger unplugged and the filter capacitors discharged...

Main Chassis Capacitor Modifications

- 1.) Replace C69 with a 0.02uf 2KV ceramic disk capacitor.
- 2.) Replace C77 with two 330uf 450V electrolytic capacitors in series. Solder a 470K 1-watt equalizing resistor across each capacitor. Epoxy the capacitors back-to-back and mount them where the original C77 was mounted. See Photo “HVCap&Grid.jpg”.
- 3.) Replace C78 with one 330uf 450V electrolytic. Mount a 2-terminal terminal strip near it and mount the capacitor vertically using fairly heavy wire to hold it in place. See Photo “LVCap.jpg”.
- 4.) Replace C51, C55, and C71 each with 0.1uf 1kv ceramic disk capacitors.
- 5.) Replace C57 with one 0.02uf 1kv ceramic disk capacitor.
- 6.) Replace C60 with one 0.005 1kv ceramic disk capacitor.
- 7.) Replace C50A and C50B each with 47uf 200V electrolytic capacitors.
- 8.) Replace C59A and C59B each with 47uf 200V electrolytic capacitors.

Note: For all terminal strips, use Radio Shack 274-688 5-lug terminal strips (4/\$1.49) and cut off unused terminals by snipping the phenolic material with wire cutters.

Now plug in the Ranger, attach a dummy load, and turn it on. After warm-up, tune it up on any band of interest. Verify operation. Check the modulator bias current. Should be 50-70 milliamps. Leave all the controls where they are when the Ranger is tuned properly. Turn off the Ranger and unplug it. Discharge the filter capacitors.

Now we’ll continue with the modifications.

VFO mods

- 1.) Remove V13 (12AU7) and V14 (6AL5) from the keyer assembly.
- 2.) Remove the keyer assembly (3 top-mount screws) and swing it out of the way.
- 3.) Remove V3 (6CL6) to gain access to the VFO side plate.
- 4.) Remove the side panel from the VFO assembly (requires removing sheet metal screws from the side panel, and two nuts underneath the chassis).
- 5.) VFO dropping resistor R3 is an 18K 2-watt resistor that is inadequate for the job and generates heat in a bad place. The power rating needs to be increased, and the resistor moved outside the VFO compartment. Locate R3 inside the VFO, and carefully clip the leads as close to the body of the resistor as possible.
- 6.) Solder 6" long insulated wires to the two cut leads remaining from the removed resistor inside the VFO assembly.
- 7.) Drill a small hole in the removed VFO side panel about where the wires should exit. Put a rubber grommet in this hole to protect the wires.
- 8.) Pass the wires through the grommet and re-assemble the VFO side panel to the VFO assembly.
- 9.) Under one of the #4 sheet metal screws holding the VFO side panel in place, attach a 2-terminal terminal strip. Solder the wires to this terminal strip, and then attach an 18K ohm 5 watt resistor to this strip. See photo "Res&Rly&Rect.jpg".

Keyer/Modulator Bias Mods (See Figures 1 & 2)

- 1.) Replace C89 with a 0.05uf 500V ceramic disk capacitor.
- 2.) Replace C90A/B with a single 47uf 200V electrolytic capacitor, POSITIVE side on ground.
- 3.) There is an unused screw hole in the aluminum keyer shelf between the two mounting post screw holes on the left edge (looking at the front panel of the Ranger) of the keyer assembly. Drill out this hole to 3/8" and mount a 10K ohm 1-watt pot in this location. See Photo "Bias&Rly.jpg" for the pot location.
- 4.) Remove R52 and R53 (both 4.7K ohm resistors).
- 5.) Solder a 2.7K ohm 1-watt resistor from the negative side of the 47uf electrolytic capacitors to the top side of the new 10K pot. Solder a 43V 1-watt zener diode from the top of the pot to ground (cathode/banded end on ground). Solder the bottom lead of the pot to ground.
- 6.) Solder the wiper of the pot to the point where R52 and R53 used to connect together. Set the pot to about mid-range.
- 7.) Connect a 1N4007 diode from 6AL5 socket pin 2 (anode) to pin 5 (cathode/banded end).
- 8.) Connect a 1N4007 diode from 6AL5 socket pin 7 (anode) to pin 1 (cathode/banded end).
- 9.) Re-install V3 (6CL6) and re-mount the keyer assembly. Plug in V13 (12AU7). V14 (6AL5) is no longer used.

Turn the function switch to Standby and let the Ranger warm up. Turn the meter to the "mod" position (full clockwise). Now turn the function switch to "phone" and quickly adjust the mod bias control (the new 10K pot) for 20 milliamps. This is a good starting point since we'll be raising all the supply voltages next, and this current will increase.

Final adjustments will reset this to the standard 50 -70 milliamps. Turn off the Ranger, unplug it, and discharge the filter capacitors.

Solid-stating the HV and LV power supplies.

For this mod, I used octal plugs (Figure 3 and Photo “Res&Rly&Rect.jpg”) with the power diodes built on them rather than solder the diodes directly to the 5R4 and 6AX5 rectifier sockets. This gives you plenty of room for the diodes as opposed to trying to pack them under the chassis. This mod will increase the voltages in the Ranger. The measured voltages (before and after the mods) were as follows:

<u>Supply</u>	<u>Tube Rectifier</u>		<u>Solid-State Rectifier</u>		
	<u>STBY</u>	<u>PHONE</u>	<u>STBY</u>	<u>PHONE</u>	<u>CW Key-up</u>
HV	616	551	756	626	660
R35 Tap	297	266	NA – Mods elim.		
LV	368	338	406	380	396

HV/LV Power Supply Mods

- 1.) Remove the filament wires from pins 2 and 8 of the 5R4.
- 2.) Series three 1N5408 1kv 3 amp power diodes from 5R4 pin 4 to pin 8. Banded ends (cathodes) towards pin 8.
- 3.) Series three 1N5408 1kv 3 amp power diodes from 5R4 pin 6 to pin 8. Banded ends (cathodes) towards pin 8.
- 4.) Series two 1N5408 1kv 3 amp power diodes from 6AX5 pin 5 to pin 8. Banded ends (cathodes) towards pin 8.
- 5.) Series two 1N5408 1kv 3 amp power diodes from 6AX5 pin 3 to pin 8. Banded ends (cathodes) towards pin 8.
- 6.) Remove R35, the 20K tapped power resistor. Connect the wire originally connected to the R35 tap directly to the output of the LV supply (plus side of “new” C78).

Note: Bleeder resistor R35 normally dissipated ~ 20 watts. However, with the effective 1-megohm bleeder resistor made up of the two 470K ohm HV capacitor equalizing resistors, the high voltage decays in about a minute with only ½ -watt dissipation.

Protecting Drive pot R13.

R13 is a 4-watt pot. It is used both for “drive” and as a LV power supply bleeder resistor. As can be determined from the voltage measurements detailed earlier, this pot is overstressed even with the tube rectifier supply (5.3 watts standby, 4.6 watts transmitting). When the power supply is solid -stated, the stress will increase even more. To significantly reduce this stress, do the following (see Photo “DrivePotRes.jpg”):

- 1) Add a 5K ohm 5-watt resistor on the ground end of R13 (sandstone colored resistor in photo).
- 2) Add a 2-terminal (one grounded) terminal strip at the R35 mounting hole location nearest the front of the Ranger.

- 3) Add a 7.5K ohm 5-watt resistor in series with the LV supply going directly to R13. Use the terminal strip just added (detailed above) for support of one side of this new 7.5K ohm resistor (black resistor in photo).
- 4) Replace the 1614 modulator tubes with 6550 tubes. The 1614 tubes were overstressed to begin with (max plate voltage spec is 500V), and now with the higher voltages, this stresses them even more. The 6550 is rated up to 800VDC on the plates. You can probably get away with using the 1614s for awhile at the higher voltage, but replace them with the 6550s as when you can.

Results: Total power now dissipated in the resistor/pot string is 4.3 watts with the solid-state power supply. Of this, only 2.8 watts is now dissipated in R13.

Transmitter check out and bias adjustment

Its time to check out all the mods and set the modulator bias current now that the voltages have all changed.

Plug in the Ranger, attach a dummy load, and turn it on, rotating the function switch quickly to “standby”. Let the Ranger warm up. Turn the meter switch to the “plate” position, turn the function switch to “phone” and dip the plate (this will have changed due to the higher voltages now available. Change the function switch back to “standby, and turn the meter switch to the “mod” position (full clockwise). Now turn the function switch to “phone” and adjust the mod bias control (the new 10K pot) for 60 milliamps. This is also a good time to check and reset if necessary R39, the VFO Keying Adjust Pot.

One last basic mod

Again, don't forget to unplug the Ranger and discharge the capacitors before beginning any modifications.

In the “tune” and “standby” positions, one end of R15 is grounded to cut off the 6146. However, R15 dissipates quite a bit of power in these cases (15 watts). I like the mod done by Tim Smith where he disconnects the 6146 screen from R15, and just directly grounds the screen in “tune” and “standby” through a relay. Under normal operation (phone and CW), the screen is re-connected by the relay back to R15. Tim also removed screen voltage from the 6AQ5 clamper when not transmitting. Tim did this as part of his PTT mods. Again, however, I'm not of the “phone persuasion”. But I went ahead and used a relay to do this anyway. I used a socketed 4PDT 120VAC relay (All Electronics 4PRLY-120L) and only used two poles of the relay. This leaves two extra relay poles for future modifications. This relay is driven by the 120VAC voltage used to drive an external relay (J5 output). Therefore, the relay is disengaged in “tune” and “standby, which grounds the 6146 screen and disconnects clamper screen voltage when the function switch is in these positions. Under normal “phone” or “CW” operation, the relay connects the 6146 screen back to R15 and re-applies clamper screen voltage. The screen voltage disconnect saves 20 watts of unnecessary power waste when in the “standby” or “tune” positions. There is also a 12VDC version of this relay available (All Electronics 4PRLY-12) so you can use that one instead should you wish to make the PTT mods. This 12V relay has the same pin-outs, though obviously you must provide a 12VDC

source for controlling it via the PTT switch. The socket (All Electronics MT14 -PC) is a surface mounting socket and attaches to the chassis with just two screws. It mounts nicely just to the inside of the 5R4 and 6AX5 rectifier tube sockets (see Photo "Bias&Rly.jpg" and Photo "Res&Rly&Rect.jpg"). Refer to the Relay Socket and Schematic details (Figures 4 and 5) at the end of this article. The mod is as follows:

- 1) Remove V3 and V4 (both 6CL6 tubes) so they aren't damaged when you drill holes for the relay socket. It might be easier to also remove the keyer assembly.
- 2) Mount the relay socket just to the inside of the 5R4 and 6AX5 rectifier tube sockets. You will need to drill two holes for mounting screws.
- 3) Disconnect the wht/grn wire (in my Ranger) from SW4A pin 6 to V5 (6146) pin 3.
- 4) Disconnect the black wire from V5 (6146) pin 3 to the bottom of R15.
- 5) Mount a 2-terminal (one grounded) terminal strip to any screw near V5. Solder a 0.01uf 1000V ceramic disk capacitor from the grounded terminal to the ungrounded terminal.
- 6) Solder a 5K ohm 5 watt resistor from the ungrounded terminal strip to V5 pin 3. You can see this resistor (blue body) just under the RF choke in Photo "HVCap&Grid.jpg".
- 7) Solder a wire from the bypassed end of the 5K ohm resistor to a common (C) relay contact on one pole of the relay.
- 8) Solder a wire from the associated normally closed (NC) relay contact to any nearby ground lug.
- 9) Solder a wire from the associated normally open (NO) relay contact to the bottom of R15.
- 10) Disconnect the mod screen/clamper screen voltage wire (originally from the 20K tapped resistor) from the LV supply. Connect this wire to a normally open (NO) relay position. Connect a wire from the LV power supply to the associated common (C) terminal of the relay.
- 11) Solder two wires from the relay AC input to J5 (the remote 120VAC connector).
- 12) Re-mount V3 and V4. Re-install the keyer assembly if it had been removed.

Optional AC cord modification

A lot of folks like to keep the original 2-wire AC cord with built-in fuses. However, I believe it is best to replace this AC cord with a proper 3-wire AC cord. As can be seen in Photo "RangerBk.jpg", I punched a 1/2" diameter hole in the chassis which would take a Radio Shack (RS-270-362) 5x20mm fuse holder with a 5-amp 5x20mm fuse to protect the Ranger. I punched a 1" diameter hole in the cabinet to clear this fuse holder.

Panel and Cabinet Restoration

Nothing tops off a boat-anchor re-build like a good panel and cabinet restoration. Dee Almquist W4PNT does outstanding work in this area. You can see Dee's work at <http://w4pnt.8k.com>. You can send the entire panel, bezel, crystal cover and cabinet to Dee for restoration. In my case, I sent the panel, bezel, and crystal cover knob to Dee, and I re-painted the cabinet myself. I found that Rustoleum Painter's Touch Kona Brown Gloss #1977 spray paint (available from Home Depot) is an EXACT match to the original paint used on the Johnson cabinet.

Conclusion

That's it – You're done. You've reduced the power dissipation of the Ranger by about 60 watts on transmit, and 80 watts in standby and tune, so you now have a cooler and much more reliable Ranger. The changes are not all that difficult to make, though I probably spent about ten hours over one weekend making these changes. Hopefully your time will be less since I've tried to detail the steps for you. For additional mods (audio and PTT), please refer to the excellent articles by WA1HLR <http://www.amwindow.org/tech/htm/rangtron.htm> and W3AM <http://www.w3am.com/ranger.html>.

Parts List

<u>Description</u>	<u>Replaces</u>	<u>Qty</u>	<u>Source</u>	<u>Cost ea.</u>
0.02uf 2KV disk cap	C69	1	Mouser 75-125LS20	\$1.89
0.01uf 1KV disk cap	New	1	Mouser 75-5HKMS10	\$0.32
330uf 450V elec.	C77, C78	3	All Elec EC-3345	\$2.75
0.1uf 1KV disk cap	C51/55/71	3	Mouser 75-10GAP10	\$1.86
0.02uf 1KV disk cap	C57	1	Mouser 75-5GAS20	\$0.48
0.005uf 1KV disk cap	C60	1	Mouser 75-5GAD50	\$0.23
47uf 200V elec. Cap	C50/59/90	5	All Elec 47/200VR	2/\$0.90
0.05uf 500V disk cap	C89	1	Mouser 75-GAS50	\$0.75
18K 5 watt res	R3	1	Mouser 71-RS5-18K	\$1.24
470K 1 watt res	New	2	Mouser 261-470K	\$0.13
Pot, 10K 1 watt	New	1	Mouser 594-249-7103	\$5.50
2.7K 1 watt res	New	1	Mouser 71-RS1A-2.7K	\$0.80
Zener, 43V 1 watt	New	1	Mouser 625-1N4755A	\$0.14
1N4007 1KV 1A	6AL5	2	Mouser 583-1N4007	\$0.04
1N5408 1KV 3A	5R4/6AX5	10	Mouser 583-1N5408	\$0.21
5K 5 watt res	New	2	Mouser 71-RS5-5K	\$0.84
7.5K 5 watt res	New	1	Mouser 71-RS5-7.5K	\$0.84
4PDT 120VAC rly	New	1	All Elec 4PRLY-120L	\$4.00
or				
4PDT 12VDC rly	New	1	All Elec 4PRLY-12	\$4.00
Relay Socket	New	1	All Elec MT14-PC	\$5.50
Terminal Strips	New	4	Radio Shack 274-688	4/\$1.49
Octal Plug	New	2	Antique Elec. P-SP8-CP8	\$0.95
6550 Tubes	1614 Tubes	2	Antique Elec. 6550A	~ \$20

Supplier info: All Electronics: www.allelectronics.com 888-826-5432

Mouser Electronics: www.mouser.com 800-346-6873

Antique Electronic Supply: www.tubesandmore.com 480-820-5411

Photos

HVCap&Grid.jpg: High voltage capacitor mounting and new screen grid resistor.

LVCap.jpg: Low voltage capacitor mounting.

Res&Rly&Rect.jpg: 18K VFO resistor, Relay, and solid state rectifiers.

Bias&Rly.jpg: New bias pot and relay.

DrivePotRes.jpg: Shows the new 5K and 7.5K drive pot “winging” resistors.

RangerBk.jpg: Shows new AC cord and fuse holder.

Ranger.jpg: Author's restored Johnson Ranger.

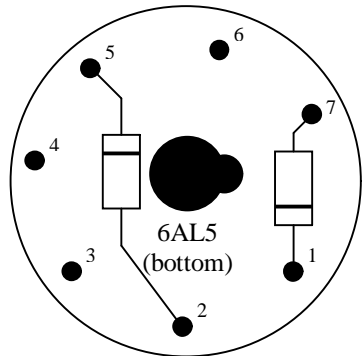

Figure 1 – 6AL5 component side (bottom) 1N4007 diode additions.

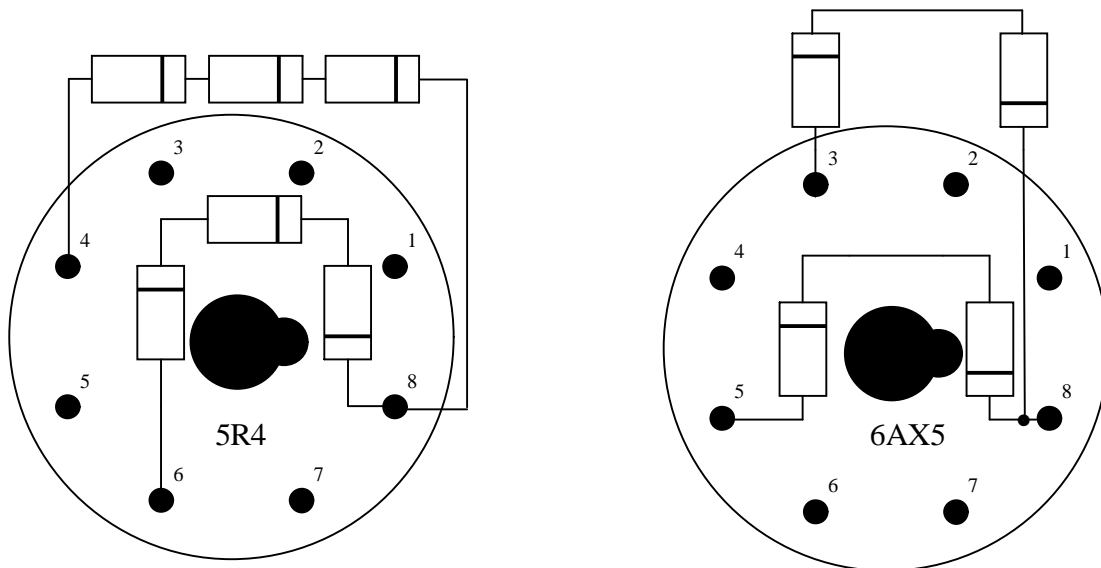
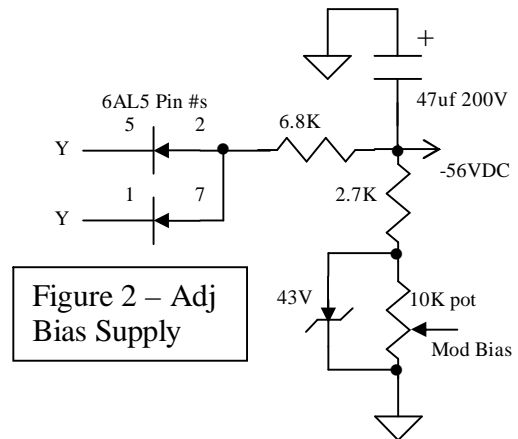

Figure 3: Rectifier Replacements – Top View (all diodes are 1N5408)

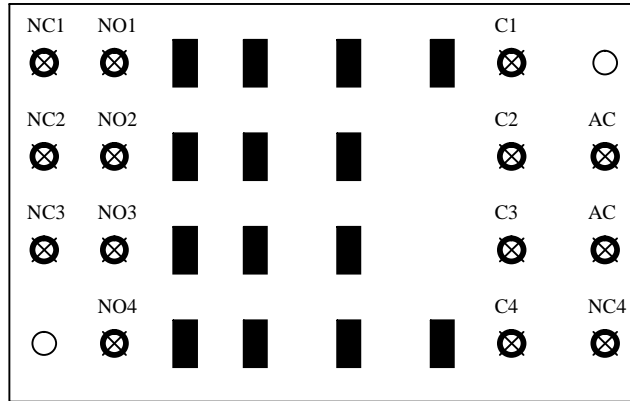

Figure 4: MT14-PC Relay Socket (Top View)

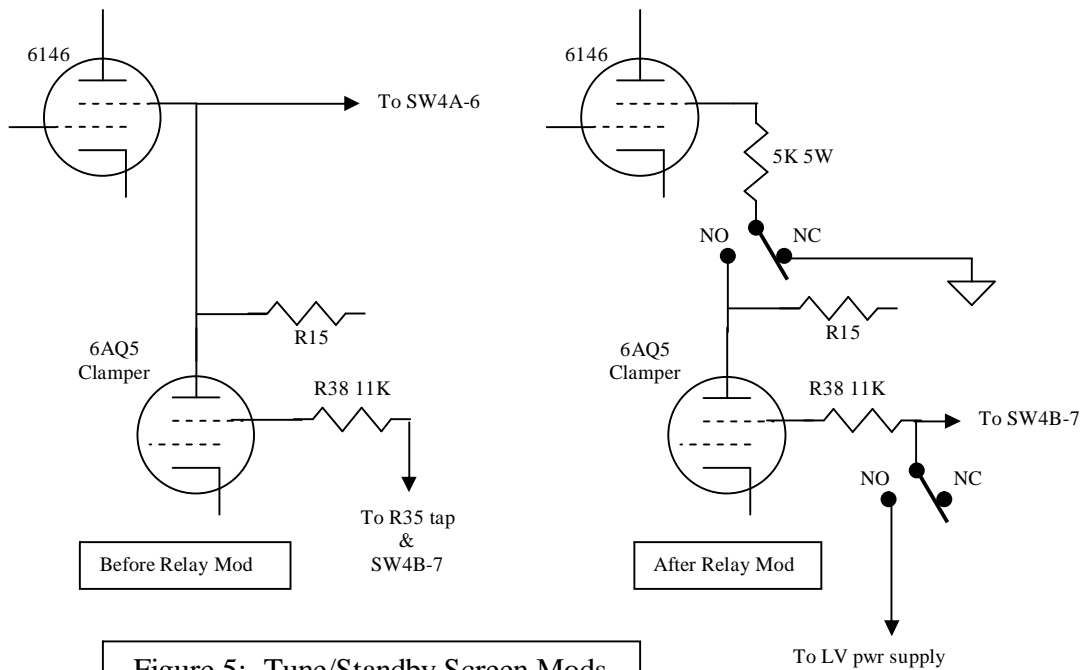
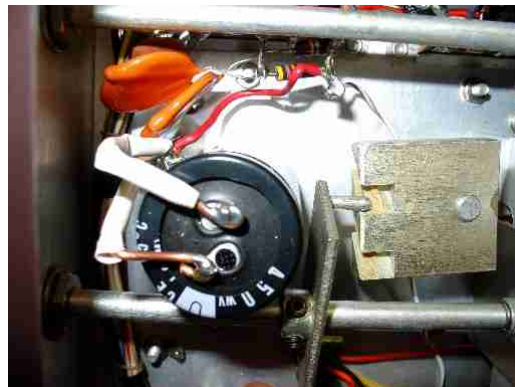

Figure 5: Tune/Standby Screen Mods



HV Capacitor and Grid Resistor



LV Capacitor



VFO resistor, Relay, and Rectifiers



Bias Adjust Pot



Drive Pot and Dropping Resistors



Ranger back