

Dummy Load/Peak Detectors

Phil Salas – AD5X

While many hams don't have a dummy load, most have an external SWR/Power meter, as well as an SWR/Power meter included inside their HF transceiver. However, this metering capability is often not provided in VHF/UHF transceivers. And even in many HF transceivers, the power/SWR metering has questionable accuracy, especially when not transmitting into a perfect 50-ohm load. As it turns out, you can easily build a dummy load/peak detector that will provide very accurate peak voltage detection through 6-meters, and can even have reasonable accuracy through 450 MHz.

How do we do this? All we need to do is add a voltage peak detector to a 50 ohm precision dummy load. Caddock thick film 15-100 watt power resistors are accurate to within 1% and typically have less than 10nhy of package/lead inductance. This makes them excellent for dummy loads into the VHF and even the UHF range when mounted properly. A simple peak detector circuit is shown in Figure 1. I used a Schottky 1N5711 detector diode which works well into the low microwave frequencies when mounted with minimal lead lengths. This diode has a typical voltage drop of 100 millivolts when measured with a digital volt meter – i.e. the peak voltage measured will be about 0.1V lower than it really is. This means that even at QRP power levels, you can get a very accurate voltage, and hence power reading. Power is easily determined as follows:

Power (watts) = $V_{rms} * V_{rms}/R$. However, we are measuring PEAK voltage. Since $V_{rms} = V_{pk}/(\text{square root of } 2)$:

Power (watts) = $V_{pk} * V_{pk}/2R$, or Power = $V_{pk} * V_{pk}/100$ when using a 50 ohm load.

30-Watt Dummy Load/Peak Detector

I first built a HF-450 MHz 30-watt dummy load/peak detector using a 30-watt 50 ohm Caddock resistor. I used a brass mounting plate as described in Figure 2. I added a 2" length piece of 1/8" x 3/4" aluminum bar stock to help dissipate the transmit power. Drill a #4 clearance hole (1/8" diameter) in the center of the bar stock, and mount it and the resistor to the brass plate. Since this unit will operate to 450 MHz, I used an N-connector rather than a SO-239. Solder the 1N5711 anode directly to the 50 ohm resistor lead and support the cathode (banded) end of the diode on the bypass capacitors soldered to the brass plate, making sure you minimize all lead lengths. Photo A shows the parts after assembly. The entire assembly is mounted in the 5/8" diameter connector mounting hole in the front of the project box as shown in Photo B. Photo C shows the completed unit.

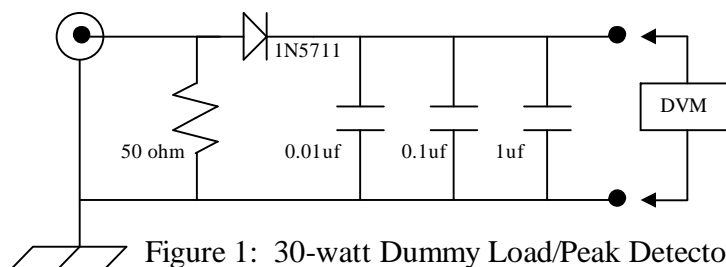

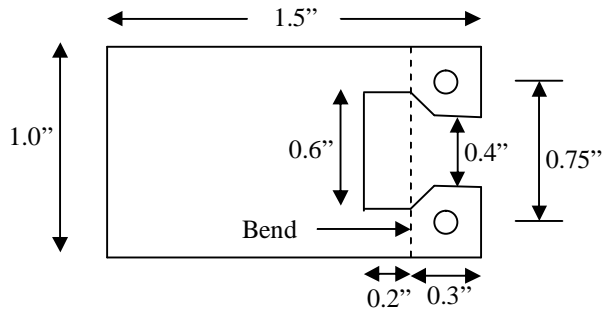

Figure 2: Brass Plate Dimensions

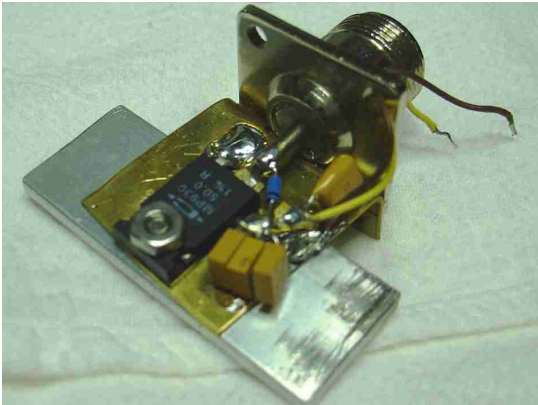

Photo A: All parts assembled

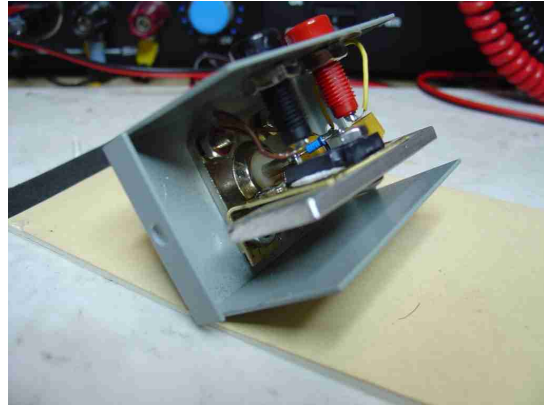

Photo B: Detector installed in box



Photo C: Completed 30-watt detector/load

So how well does this unit work? I measured the SWR as 1:1 through 6-meters, 1.2:1 at 2-meters, and 1.3:1 on 450 MHz. I used a MFJ-259B, an Array Solutions AIM4170, and a MFJ-219B antenna analyzer to measure SWR. I verified accuracy by connecting 3dB and 10dB precision Weinschel shorted attenuators to the antenna analyzers (3:1 SWR for 6dB return loss, and 1.2 SWR for 20 dB return loss). Since V_{pk} -squared is directly proportional to SWR, and power is directly proportional to V_{pk} -squared, your power calculation could be off as much as 20% on 2-meters and 30% on 450 MHz, assuming your radio puts out constant power into these slightly mismatched loads. On 6-meters and below however, the accuracy will be very good.

Parts List: 30-watt HF-450 MHz 50 ohm Detector

<u>QTY</u>	<u>Description</u>	<u>Source/Part Number</u>	<u>Price ea.</u>
1	500 30-watt resistor	Mouser 684-MP930-50	\$3.62
1	2.25x1.5x1.38" box	Mouser 537-M00-P	\$3.99
1	N Chassis Mount	Mouser 530-CP-AD801	\$6.44
1	1N5711 Schottky	Mouser 511-1N5711	\$0.10
1	0.01µf 100V cap.	Mouser 581-SR151C103KAR	\$0.14
1	0.10µf 100V cap.	Mouser 581-SR201C104KAR	\$0.18
1	1.0µf 100V cap.	Mouser 581-SR301E105MAR	\$0.63
1	Red tip jack	Mouser 530-105-0802-1	\$0.66
1	Black tip jack	Mouser 530-105-0803-1	\$0.66
1	0.032" brass sheet	ACE Hardware	
1	3/4 x1/8x2"AL bar	ACE Hardware	

200-Watt Dummy Load/Peak Detector

The previous dummy load/wattmeter was limited to 30-watts due to both the thick film resistor used, and the peak voltage rating of the detector diode. The 1N5711, as well as popular germanium detector diodes, is limited to 70-volts peak voltage. The peak voltage for a 100-watt transceiver is 100-volts:

$$V_{pk} = \text{square-root}(2 \times PWR \times Z_o) = \text{square-root}(2 \times 100 \times 50) = 100 \text{ volts}$$

An easy way to get around this problem is to put two 25-ohm resistors in series, and place the detector diode at the resistor junction as shown in Figure 3. Now the peak voltage at 100-watts is 50-volts. At 200-watts the peak voltage is 70-volts. So using two 100-watt thick film resistors, we can build a dummy load/peak detector with up to a 200-watt capability. Since we're detecting half the actual peak voltage, the relationship of detected voltage to transmit power can be determined as follows:

$$V_{pk} = V_{det} \times 2$$

$$V_{rms} = V_{det} \times 2 / (\text{sqr root } 2)$$

$$PWR = V_{rms}\text{-squared} / 50 = \{ [V_{det} \times 2 / (\text{sqr root } 2)]\text{-squared} \} / 50 = (V_{det}\text{-squared}) / 25$$

The 200-watt dummy load/peak detector is physically different than the 30-watt unit. The two 25-ohm thick film resistors are each much larger than the single 30-watt 50-ohm resistor, and you must get rid of a lot of heat. To help get rid of the heat, I used the inexpensive microprocessor heat sink/fan assembly called out in the part's list. This heatsink/fan assembly fits the aluminum box almost perfectly! The blue wire on the fan can be removed, and I added a Powerpole connector so as to interface with all my other 12V devices and power sources.

To ensure maximum heat transfer from the thick-film resistors, it is important that they be mounted on a flat surface. Therefore, I mounted the resistors directly on a 1/8" piece of aluminum bar stock. I drilled two #6 clearance holes through the bar stock and aluminum box where the resistors will be mounted, and one #4 clearance hole through the box where a terminal strip will mount. Next I marked, and then drilled and tapped

two #6 screw holes and one #4 screw hole in the heatsink/fan assembly which match the clearance hole placement. The #6 mounting screws sandwich the box and barstock between the thick-film resistors and the heatsink/fan assembly, and the #4 screw attaches the terminal strip through the box to the heatsink/fan assembly. You can see details of the component mountings in Photo D. Photo E shows the heatsink/fan assembly mounted on the back of the dummy load/peak detector. Photo F is a view showing the UHF connector and the peak voltage monitoring connectors.

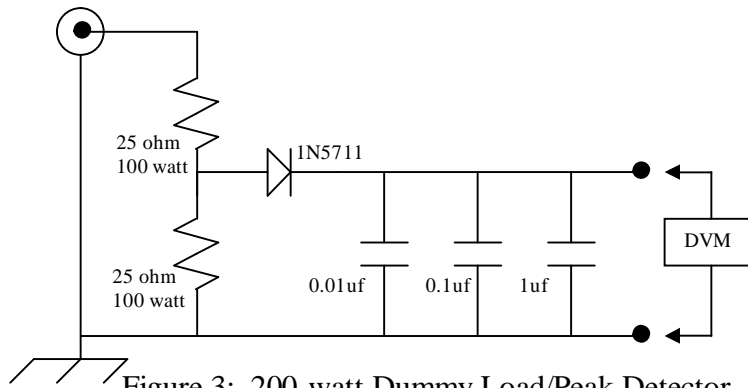

Figure 3: 200-watt Dummy Load/Peak Detector



Photo D: Component mounting



Photo E: Heat sink/Fan assembly



Photo F: Final assembly

That's about it. The measured SWR was 1:1 from 1.8-54 MHz, so the detected voltage will be quite accurate. You can run 100-watts into the dummy load for maybe 30

seconds without the fan powered up before the dummy load gets too hot, however it is always best to run the fan.

Parts List: 200-watt HF-50 MHz 50 ohm Detector

<u>QTY</u>	<u>Description</u>	<u>Source/Part Number</u>	<u>Price ea.</u>
2	250 100-watt resistor	Mouser 684-MP9100-25	\$9.14
1	1N5711 Schottky	Mouser 511-1N5711	\$0.10
1	0.01 μ f 100V cap.	Mouser 581-SR151C103KAR	\$0.14
1	0.10 μ f 100V cap.	Mouser 581-SR201C104KAR	\$0.18
1	1.0 μ f 100V cap.	Mouser 581-SR301E105MAR	\$0.63
1	3.25x2.13x1.63" box	Mouser 563-CU3001A	\$4.75
1	Red tip jack	Mouser 530-105-0802-1	\$0.66
1	Black tip jack	Mouser 530-105-0803-1	\$0.66
1	Heat sink grease	Mouser 590-8461-85ML	\$6.95
1	SO-239 connector	All Electronics SO-239	\$1.00
1	Fan/Heatsink Assy.	All Electronics CF-271	\$3.50
1	Terminal strip	All Electronics TP-70	10/\$1.00
1	3/4x1/8x3" AL bar	ACE Hardware	
Miscl	#4 & #6 hardware	ACE Hardware	