

Remote DC Power through your Coax Cable

Phil Salas – AD5X (ad5x@arrl.net)

Introduction

Do you need to get DC from your shack out to your antenna for a remote antenna tuner, remote relay, etc.? If so, the DC IN/OUT boxes discussed here will let you inject 12VDC power into the rig end of the coax, and recover it at the remote end of the coax cable.

The Design

Injecting DC onto a coax cable requires good RF isolation between the signal and the DC source, since the DC source looks like a ground, or short, to the RF signal. So an inductor must provide a high RF impedance, and also handle the DC current required. The JW Miller 4632 (Mouser 542-4632) inductors used here handle 400ma and provide a high Q such that full legal limit can be used from 160-2 meters. No inductor resonances occur over this range. The 0.01uf coupling capacitors should be 3KV rated (Mouser 581-5ST103MCMCA). While the coupling capacitor voltage rating is not critical since there is little voltage drop in this application, the large physical size of these capacitors makes it easy to dissipate any power dissipated due to any capacitor losses. For operation on 160 meters, parallel three 0.01uf capacitors for best performance.

The rest of the design is straightforward. I fused the input at ½-amp since this is the just above the current rating of the inductors. A 1N4001 diode oriented as shown in Figure 1 protects against reverse voltage. Both high-and low-frequency bypass capacitors (0.01uf, 0.1uf and 4.7uf) are used on the DC side of the inductors as shown in Figures 1 & 2. On the output box, a 15 volt zener diode clamps any voltage spikes should they occur. Keep your signal-carrying lead lengths as short as possible, though this is not too critical at HF.

Refer to the photos to help with your assembly. I used a pig-tail coax cable for the connection to my transceiver. This is obviously an alternative to the SO-239 interface shown on the schematic. I labeled the two boxes with Casio “black on clear” tape. I also used a permanent marker pen to draw an RF/signal flow direction arrow on both boxes.

Build the DC output circuitry into a weatherproof electrical 3-hole ½-inch outlet box. The blank panel comes with a weather resistant seal. Two ½-inch plugs are supplied, so you need a third plug – that’s the reason I show an additional package of plugs in the parts list. All circuitry is built onto the blank cover as is seen in Photos C and D. I also connected a ground wire between the panel and the outlet box ground, though the panel screws are probably fine for providing ground between the two assemblies.

The screws that come with the blank panel are NOT stainless steel, therefore replace these screws with #6 stainless steel flat-head screws. Also use #6 stainless steel hardware to mount the terminal strip to the blank panel. To weatherproof the DC output cable, punch a ¼” hole in the blank panel and pass the DC cable through it. Apply hot glue to the inside of the blank panel, letting a little hot glue seep through the hole. Then apply liquid electrical tape to the outside of the blank panel around the exiting DC cable. Also

apply epoxy and/or liquid electrical tape around the SO-239 connectors to weatherproof them as well. Finally, install the three ½” plugs into the outlet box.

Conclusion

This article describes simple circuitry for injecting DC voltage on the rig side of your coax, and recovering the voltage at the other end of the coax. Measured performance is excellent from 1.8-148 MHz at up to full legal limit.

Parts List

<u>QTY</u>	<u>Description</u>	<u>Source</u>
2 (or 6)	0.01uf 3KV cap.	Mouser 581-5ST103MCMCA
2	100 uhy RF choke	Mouser 542-4632
2	0.1uf 50V cap.	Mouser 581-SR215C104KAR
2	0.01uf 50V cap.	Mouser 581-SR215C103KAR
2	4.7uf elec. cap.	Mouser 647-UVR1H4R7MDD
1	15V zener diode	Mouser 821-1SMA4744
1	5x20mm ½-amp fuse	Mouser 504-GMA-1/2
1	5x20mm fuse holder	Mouser 504-HTB-22M
1	Aluminum box	Mouser 563-CU-3000A
1	Terminal strip	Mouser 158-1005
4	SO-239	Mouser 601-25-7350
1	Grommet	Mouser 5167-159
2	Pair Powerpole	www.powerwerx.com
1	Outlet box	Red Dot RIH31LM (Home Depot/Lowes)
1	Blank Cover	Red Dot RCCB (Home Depot/Lowes)
1 pkg	½” plugs	Red Dot S603E (Home Depot/Lowes)

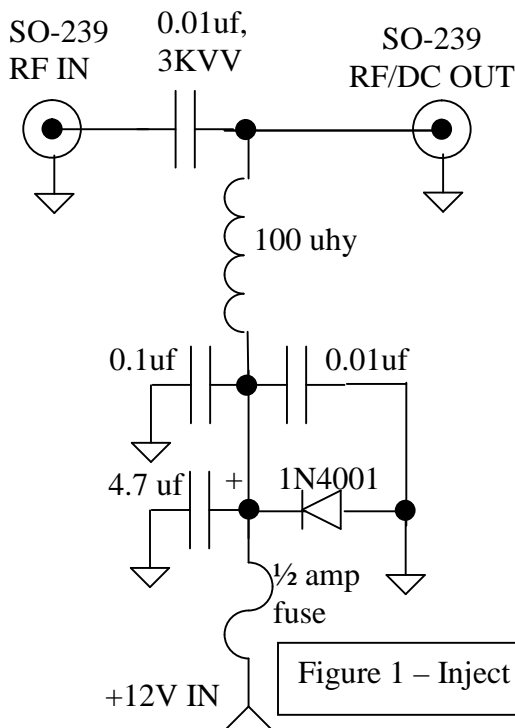

Figure 1 – Inject DC

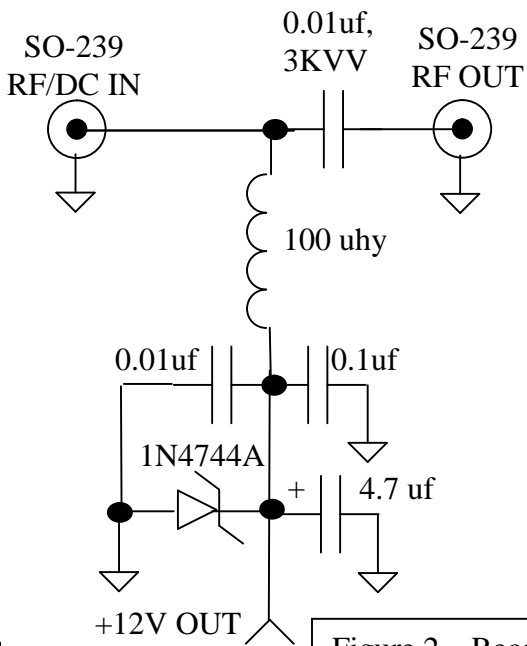

Figure 2 – Recover DC

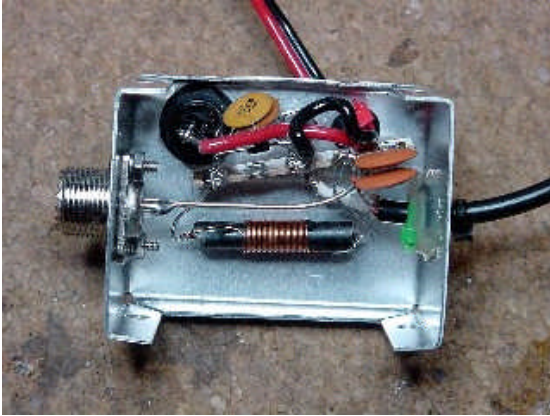

Photo A: DC In (internal view)

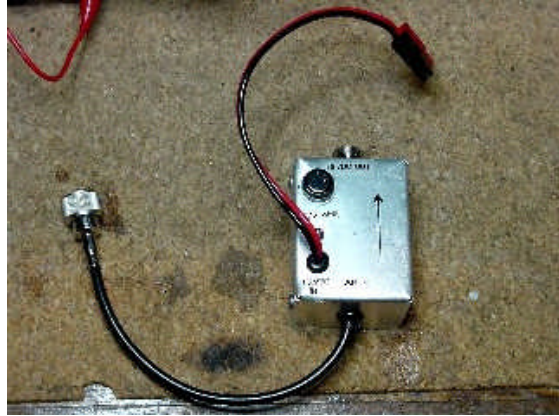

Photo B: DC In (external view)



Photo C: DC Out (internal view)



Photo D: DC Out (external view)