

Absorptive SWR Indicator with IC-706/703 Keying for the MFJ-902 Antenna Tuner By Phil Salas – AD5X

Introduction

The MFJ-902 is a very compact antenna tuner that is small, has a large tuning range, and handles transmitter power levels up to 150 watts from 80- through 10-meters. It even includes a bypass switch on the back panel so you can take it off-line when your antenna system doesn't need trimming.

The MFJ-902 does not include an SWR indicator, since most rigs today include this capability as a metering display option. However, I prefer an SWR indicator in my antenna tuners, since I don't like to have to make any menu changes on my portable rigs during tune-up.

The SWR Indicator

A very simple SWR circuit is the absorptive SWR circuit. This is simply a resistive 50-ohm bridge (see Figure 1). An advantage of this circuit is that it protects your transmitter from high SWR conditions while tuning, since the worst SWR your transmitter can ever "see" is 2:1. The disadvantage, however, is that you must find resistors capable of dissipating up to 75% of your tune-up power – as well as find space for these resistors.

In the Mouser Electronics catalog (www.mouser.com), I found power film resistors made by Caddock that can handle from 15 to 100 watts of power, depending on the resistor type. These are non-inductive power resistors and provide an excellent resistive load across the HF bands. I used the 50-ohm 15-watt resistors which come in a TO-126 package. Of course, you need to properly heat-sink these resistors in order to permit them to dissipate their rated power. If you want a little more power dissipation, there is a 30-watt TO-220 packaged version available (Mouser 684-MP930-50 at \$3.58 each). There are also 60 watt and 100 watt resistors for higher powers, but there is limited room inside the MFJ-902 and the smaller TO-126 package is more appropriate for this particular application. Also, if you put a full 100-watt transmit output power into this circuit, you are talking about serious heat dissipation – something not practical in the compact MFJ-902. More resistor separation and external heat-sinking would be required.

The two portable radios I use are an IC-706MKIIG and an IC-703. I didn't want to do anything special (i.e. adjust power) during tuning when using these rigs with the MFJ-902. Therefore, I decided to add keying to the MFJ-902 that would key these particular radios in their 10-watt tune mode. I used a red ultra-bright LED as the relative SWR indicator. I selected the LED current limiting resistor to be 10K ohms – but you can reduce this value if the LED is not bright enough for you.

Adding the bridge and keying circuit to the MFJ-902

First, gather up the necessary parts as shown in Table 1 below.

TABLE 1 – SWR Bridge/IC-70X Keying Parts

<u>Qty</u>	<u>Ref</u>	<u>Description</u>	<u>Source</u>	<u>Cost ea</u>
3	R1/R2/R3	50 Ω 15-watt res	Mouser 684-MP915-50	\$2.78
1	S1	DPDT Slide Switch	Mouser 629-GF11261110	\$1.08
1	S2	DPDT Slide Switch	AllElectronics SSW-37	4/\$1.00
3	C1/C2/C3	0.01 uf capacitor	AllElectronics 103D50	10/\$0.60
2	R4/R5	10K ¼-watt res	AllElectronics 10K	\$0.05
1	D1	Super Bright LED	AllElectronics LED-94	\$0.75
1	D2	1N4148 diode	AllElectronics 1N4148	15/\$1.00
1		Connector	Radio Shack 274-224	\$1.29
1		Terminal strip	Radio Shack 274-688	\$1.29/4
1		Heat sink grease	Radio Shack 276-1372	\$1.99
3		#2 screws	Radio Shack 64-3010	\$1.49/pk
3		#2 nuts	Radio Shack 64-3017	\$1.49/pk

The first photo shows the internal unmodified tuner. Refer to photo “MFJ-902 Modified” and Figure 2 to determine the best way to place all the new parts. Clip off any unnecessary lugs on the terminal strip (or wire everything without the terminal strip). The 50-ohm 15-watt resistors are mounted with #2 hardware. Apply heat-sink grease to the bottom of each resistor to ensure good heat-sinking. You will also need to add a ground connection to the right of the right-most 50-ohm resistor as shown. Finally, make sure you keep all components clear of the “transmitter” variable capacitor so there is no interference with the capacitor when it is rotated. I used slide switches, but you may prefer toggle switches (see my original October 2004 QST article) since they are easy to mount (round holes are easier than rectangular holes). The slide switches are lower profile. If you use slide switches, the Craftsman 96757 Needle File Set will make your life easier.

The super-bright SWR indication LED is mounted on the upper left corner of the front panel as shown in the photos. Run the LED wires under the left variable capacitor and hold them to the bottom of the cabinet with hot glue. Also use hot-glue to hold the LED in place. I labeled the new switches on the back panel with Casio labeler with “white on clear” tape. See photo “Final Back”.

Operation

To operate the modified MFJ-902, flip the SWR switch to “SWR”, key your IC-70X with the “IC706 Tune” switch, and then adjust the tuner controls until the front LED SWR indicator goes out. This is as easy as using an analog meter. When the SWR is good, flip the SWR switch to “XMT” and unkey the “IC706 Tune” switch.

So how does this work? In a word, great! With switched inductor tuners, I’ve always worried about the momentary high SWR incidents that occur as you switch the inductor, so I’ve tended to un-key the transmitter before making inductance changes. With the absorptive bridge in the modified MFJ-902, I no longer worry about this. I did check the SWR (tuner bypassed playing into a good 50 ohm load) with and without the new circuitry and saw no difference across the HF bands. So the added lead lengths and

circuitry have no noticeable effect on the bypassed tuner performance. Now, I wonder if there is a way I can fit a balun inside that MFJ-902 case....

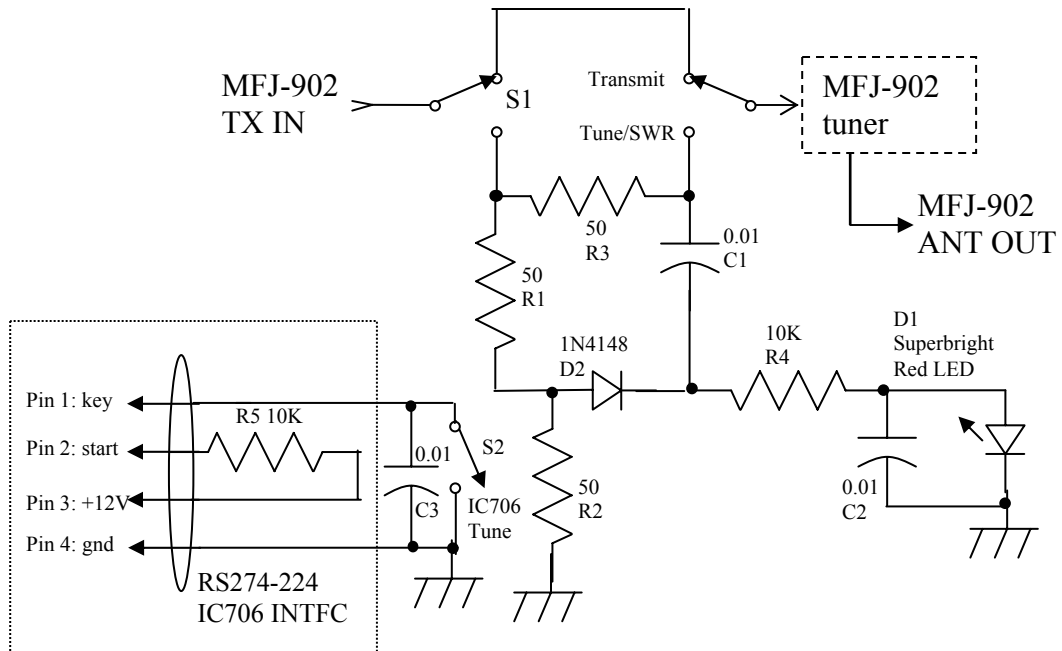

Figure 1 – Resistive SWR Bridge/IC-70X Interface for the MFJ-902 Antenna Tuner

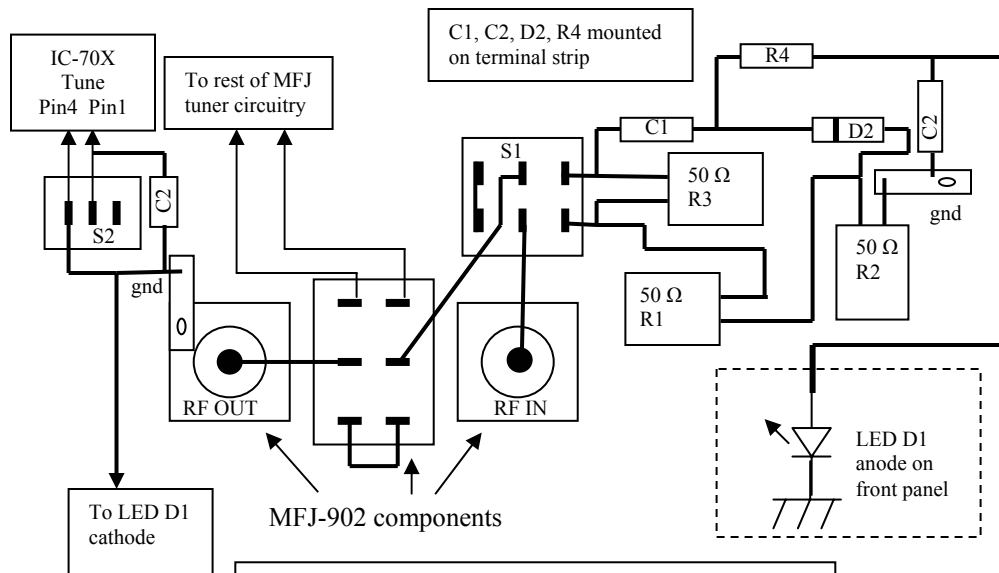

Figure 2 – Internal wiring/parts placement



MFJ-902 Unmodified



MFJ-902 Modified

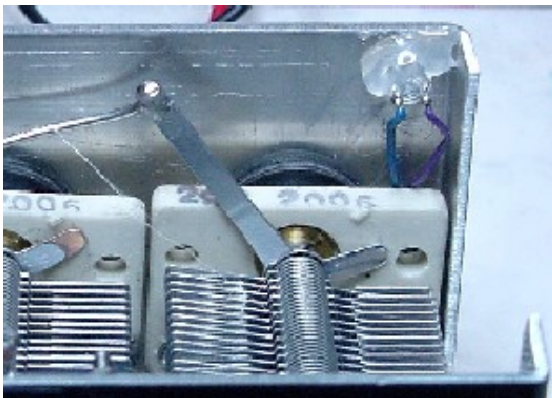

LED mounted – inside view



New backside



SWR LED on front



Portable Station